

Electric Curtain Track Systems

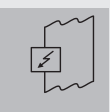



Electric Curtain Track System

Silent Gliss® 5400

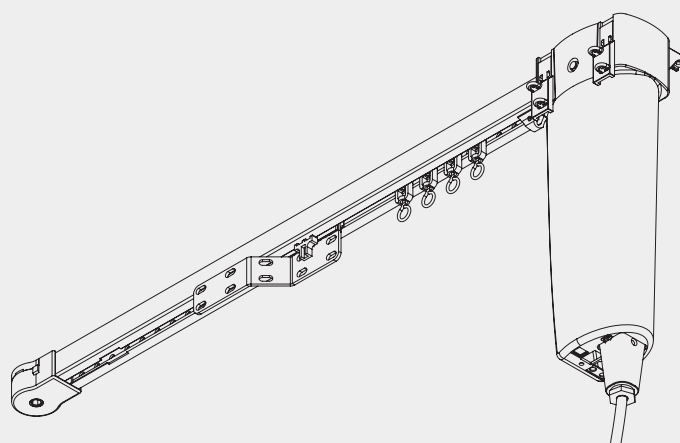

Product Information

- Motorised curtain track system for contract and residential use
- The system 5400 is equipped with motor 9020/9021 (90-260VAC)
- Option of integrated radio receiver compatible with Silent Gliss radio remote control system 9940/0450
- Various other operating methods available; see motors/controls overview chart and the specific motor variations section
- It can be also equipped with the unique manual override feature
- Stacking: single, pair and equal multiple stacks
- Easy ceiling or wall fix. Recess fixing possible. The motor can also be mounted above the profile
- Standard colours: white powder coated or anodised aluminium, bronze and black
- Supplied assembled
- Curtain travel speed 16cm/sec
- Exceptionally quiet motor (<45dba (30cm))
- Available with Wave Standard and Wave XL curtain heading systems
- 0900 timer option available
- Can be combined with Silent Gliss 50mm decorative pole system (straight tracks only)



5400

Profile and Bending Information

Main profile

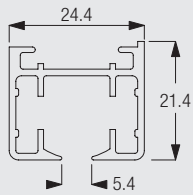

2191



Minimum radius 250mm
Wave XL: Min. radius 500mm

Recess profile

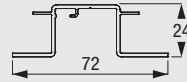

5117



Note: It is important to observe the minimum bending radius for Wave XL. The system will not function with a smaller radius.

Specification Guide - download from www.silentgliss.co.uk (password required).

Silent Gliss 5400 electrically operated curtain track, interference free with a built in low voltage interface allowing direct access to all automated control systems with memory for easy limit setting, anodised aluminium/powder coated, complete and assembled with motor 9020/9021, internal drive belt, belt guide/returns and roller gliders 6098 at 10/m / Wave glider cord, 2191 profile top fixed with 3825 fixing clamps at approx 600mm centres, each clamp screwed to timber. With/without integrated radio receiver, wiring (by others measured elsewhere) to be strictly in accordance with Silent Gliss wiring diagrams.Lm inlengths.

How to Measure

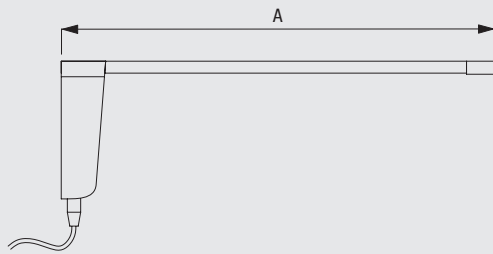

A: System width

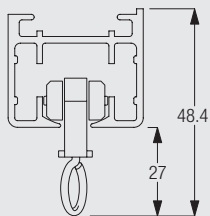
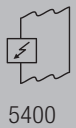
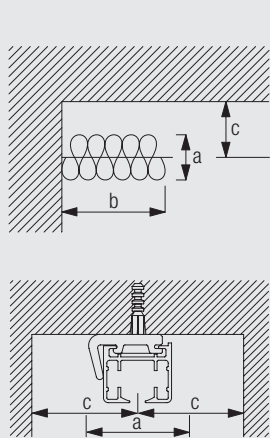

Diagram uses standard gliders (6098) measured to the inside of the glider eye.

Stack Size Calculation Wave Standard



a = Stack depth
b = Stack size
c = Min. distance

Wave standard

Glider-cord spacing	Curtain hook spacing	Approx. curtain fullness	Stack depth (a)	Stack width (b)	Min distance (c)
6	10	1.9	10	23 per metre of track + endpiece	8
6	12	2.2	12	23 per metre of track + endpiece	9
8	14	2.0	14	18 per metre of track + endpiece	10
8	16	2.2	16	18 per metre of track + endpiece	11

Wave standard with roller gliders

Glider-cord spacing	Curtain hook spacing	Approx. curtain fullness	Stack depth (a)	Stack width (b)	Min distance (c)
8	14	2.0	14	21 per metre of track + endpiece	10
8	16	2.2	16	21 per metre of track + endpiece	11

(dimensions in cm)

Note: Minimum distance (c) includes a standard 4.5cm clearance (front and back).

Stack size calculation Wave XL

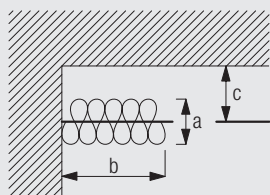

a = Stack depth 35cm
b = Stack size
c = Min. distance 22cm

System width		77-107	108-143	144-179	180-215	216-251	252-287	288-323	324-359	360-395
	b	31	36	41	46	51	56	61	66	71
System width		396-431	432-468	469-503	504-539	540-575	576-611	612-647	648-683	684-719
	b	76	81	86	91	96	101	106	111	116
System width		720-755	756-791	792-827	828-863	864-899	900-935	936-971	972-1000	
	b	121	126	131	136	141	146	151	156	
System width		154-217	218-289	290-361	362-433	434-505	506-577	578-649	650-721	722-793
	b	31	36	41	46	51	56	61	66	71
System width		794-865	866-937	938-1000						
	b	76	81	86						

(dimensions in cm)

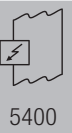

5400

System Dimensions



10m



44kg, (Basis: System 2 m, straight with rollers)

Max. Curtain Weight Chart Standard Glider/Optional Wave Roller Glider

Standard Application with Rollers

	2 m	4 m	6 m	8 m	10 m
	44	42	40	38	36
	44	42	40	38	36
	40	36	31	27	22
	40	36	31	27	22
	32	28	24	20	16
	32	28	24	20	16
	20	18	16	-	-
	20	18	16	-	-

(kg max.)

Please note: table above assumes curtain heading is completely below the profile. It is essential with electrically-operated curtain tracks to choose a system which can readily cope with the specific demands placed on it. The most crucial factor is the total weight of the curtains transported by it, but then come further questions such as how the curtains are stacked, are there bends involved, ceiling or wall fix, the type of curtain heading etc.

Please refer to load graphs on the application chart.

Max. Curtain Weight Charts Wave Standard / Wave XL and Manual Override

Option Wave / Wave XL

	2 m	4 m	6 m	8 m	10 m
	5	10	15	15	15
	5	10	15	15	15
	5	10	15	15	15
	5	10	15	15	15
	5	10	15	12	8
	5	10	15	12	8
	5	10	12	-	-
	5	10	12	-	-

(load limitation max. 2.5 kg per m)

Option Manual Override

	2 m	4 m	6 m	8 m	10 m
	6	12	18	20	20
	6	12	18	24	29
	6	10	10	10	10
	6	12	18	18	15
	6	10	10	10	8
	6	12	18	12	8
	6	10	10	-	-
	6	12	12	-	-

(load limitation max. 3 kg per m)

Manual override is not applicable when Wave or Wave XL curtain heading systems are used.



5400

System Options

Wave Standard curtain heading system

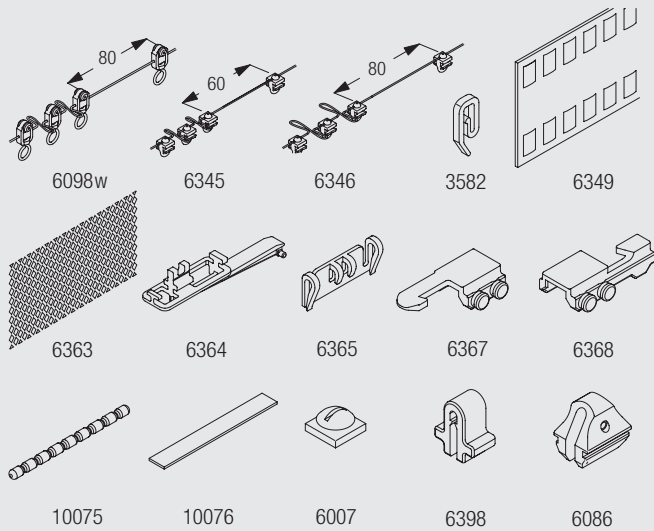
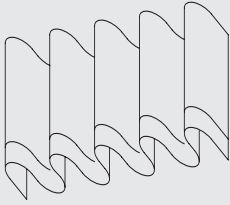

System 5400 is compatible with Wave - an exciting new contemporary curtain heading system which allows curtains to hang in a continuous wave which is smooth, simple and elegant.

When using the Wave curtain heading system please note the maximum recommended curtain weight is 2.5kg/m. **A greater weight may be achieved using wave roller glider 6098W (refer to System Dimensions).**

Not applicable in combination with the Manual Override option.

The Wave standard components are:

- 3582 Hook
- 6007 End stop
- 6345 Glider Cord 60 mm
- 6346 Glider Cord 80 mm
- 6349 Curtain tape
- 6363 Iron-on top hemming tape
- 6364 Extension (for use with 6365)
- 6365 Hanger (for use with 6364)
- 6367 Master carrier
- 6368 Carrier
- 10075 Lead weight (50 gr/m) for bottom hem

Additional optional components are:

- 10076 Fabric weight for side of curtain
- 6098W Roller glider cord 80mm

Wave XL curtain heading system

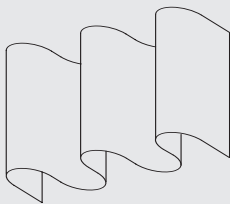

Wave XL is especially designed for high and large application areas through generously designed waves with large cross section dimensions.

Not applicable in combination with the Manual Override option.

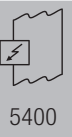

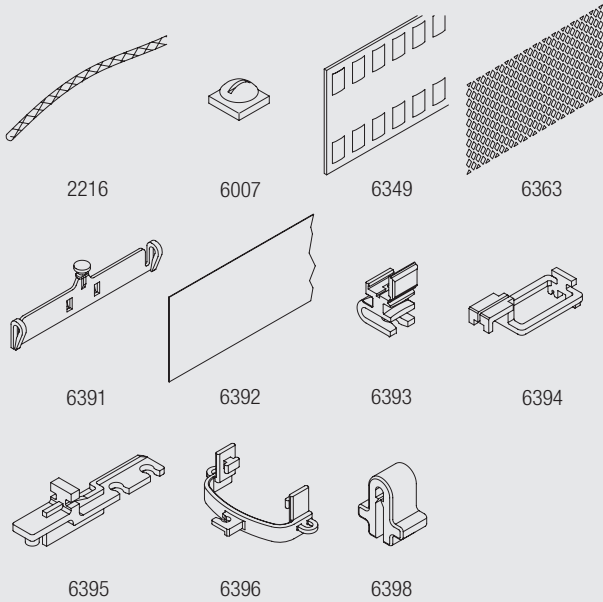

The Wave XL components are:

- 2216 Cord 0.85 mm
- 6007 End stop
- 6349 Curtain tape
- 6363 Iron tape
- 6391 Hanger
- 6392 Heading film
- 6393 Glider
- 6394 Carrier
- 6395 Extension
- 6396 Mask

Additional optional Wave components:

- 6398 Clip

Manual Override

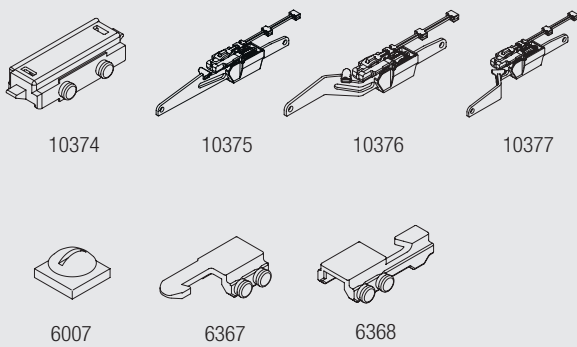

This option protects the fabric and the system if curtain encounters an obstacle or is operated by hand.

Manual Override is not applicable when Wave or Wave XL curtain heading systems are used.

The Manual override option includes the following parts, depending on how the system is used:

- 10374 Carrier set
- 10375 Manual override straight set
- 10376 Manual override left set
- 10377 Manual override right set
- 6007 End stop
- 6367 Master carrier
- 6368 Carrier

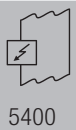

5400

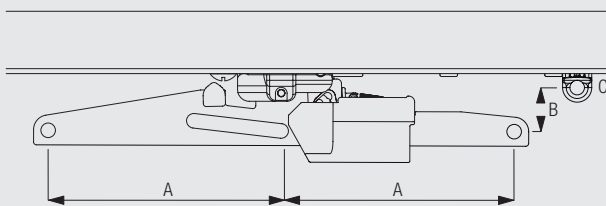

- A: 80mm
- B: 15mm
- C: Glider 6083

Decorative pole option (system 6150)

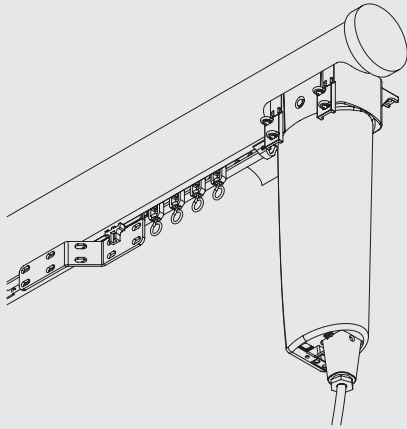

System 5400 can be combined with the Silent Gliss 50mm decorative pole in silver, white, steel grey and black finishes. For further information refer to the Decorative Curtain Poles catalogue (www.silentgliss.co.uk).

Fitting Information

For all electrically operated curtain track systems, a connection point should be made available at a distance of no greater than 1 metre from the motor. This should be discreetly situated behind the curtain, taking care that the motor will not obstruct access to the socket.

Bracket and profile positioning

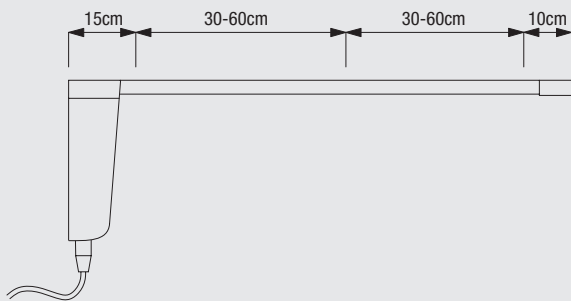

Higher edge of profile to the room side.



5400

Motors can be recessed in hollow ceilings

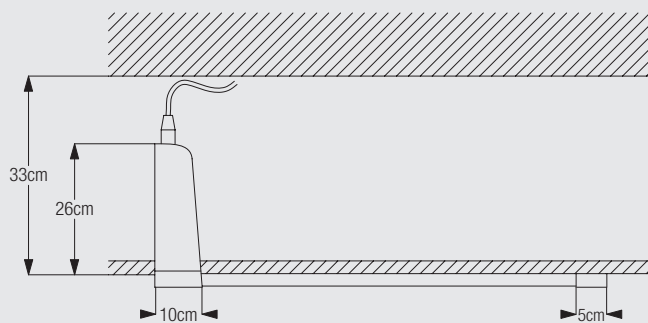

With profile surface mounted with clamp 3825 or bracket 3826/3832 on the ceiling.

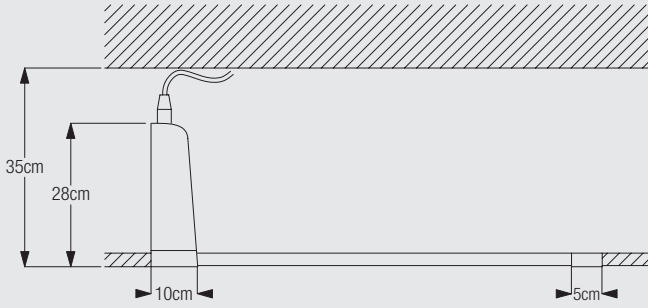

With profile 5117 recessed into ceiling.

Where the system is to be fitted to the ceiling, (recommended in most cases), the surface must be absolutely flat. Any unevenness will cause problems in fitting the clamps and will almost certainly affect the functioning of the system.

Fitting Options

Ceiling fix with clamp 3825

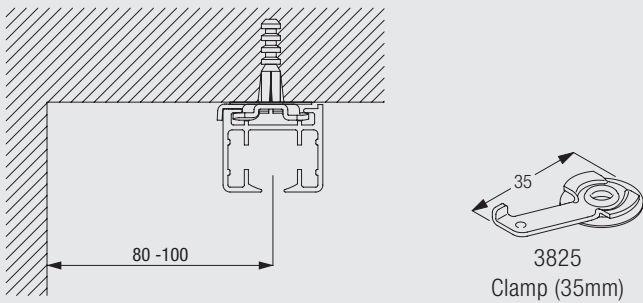

Min. distance from wall when using Wave XL: 220 mm.



5400

Ceiling fix with bracket 3826

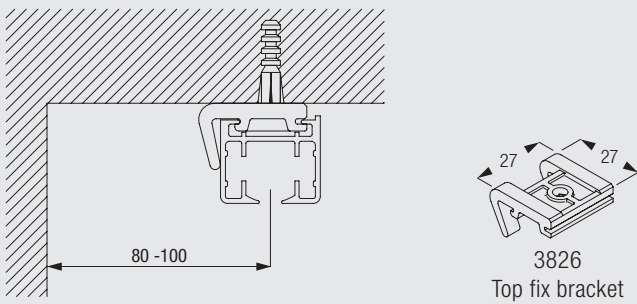

Min. distance from wall when using Wave XL: 220mm.

Ceiling fix with bracket 3832

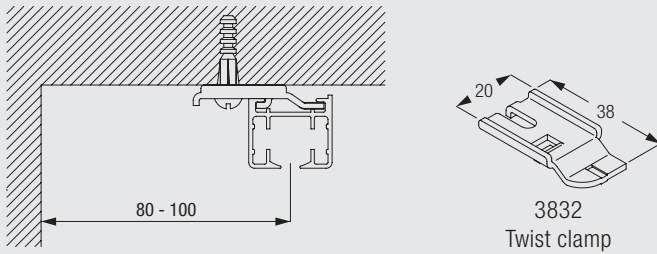

Min. distance from wall when using Wave XL: 220mm.

Recess fix with recess profile 5117

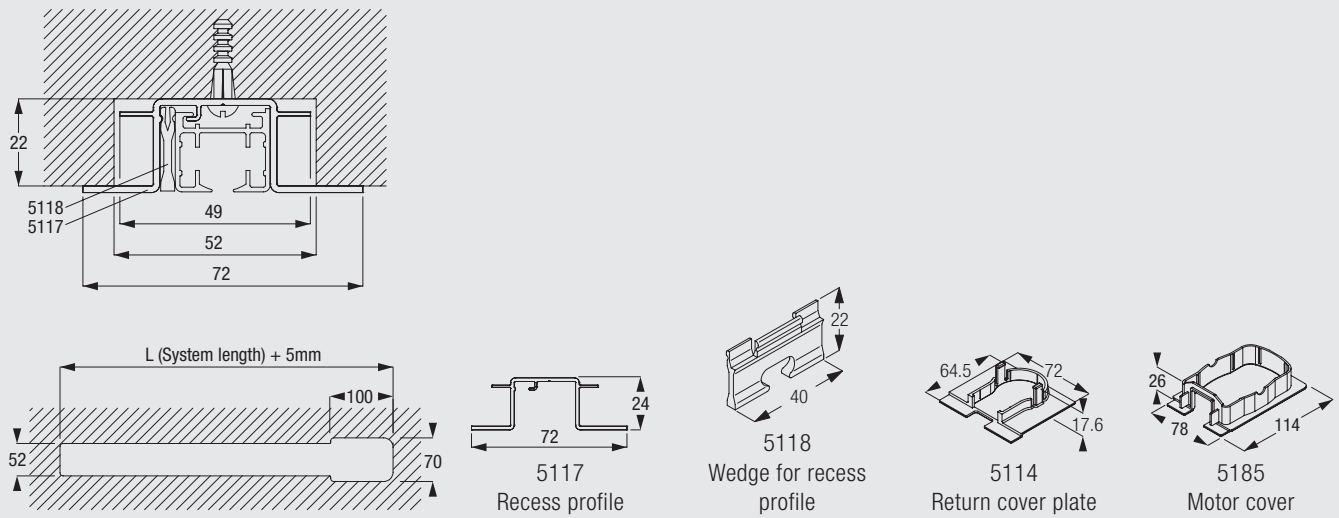

Ceiling cut out detail.

Min. distance from wall when using Wave XL: 220mm.

Wall fix with bracket 3836

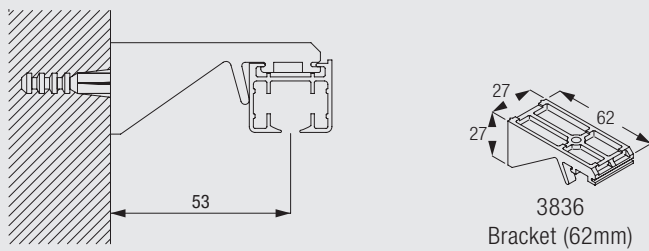

Wall fix with brackets 3134-39 and bracket 3826

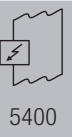
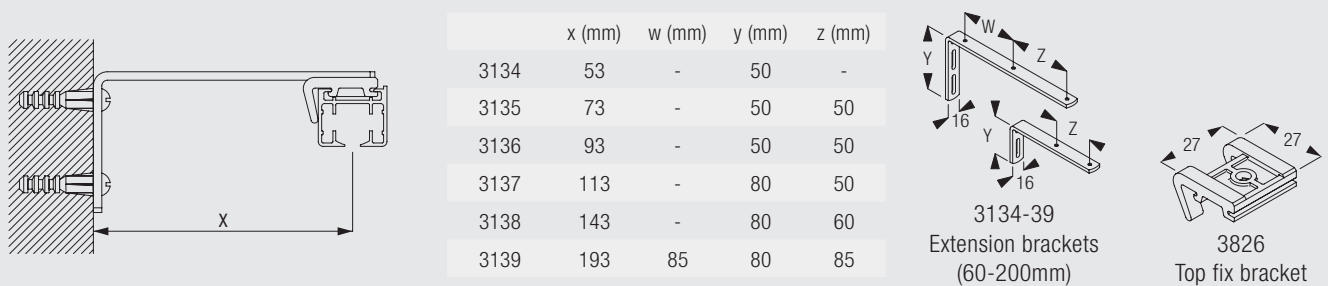

Brackets feature thread for screw M4x8 (6748) for fixing the bracket 3826.

Wall fix with adjustable brackets 3275-77

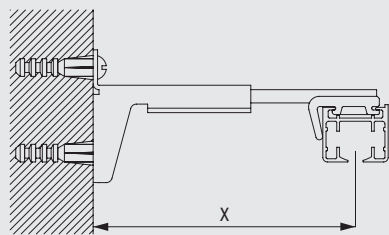

	x (mm)
3275	72-94
3276	86-117
3277	117-148

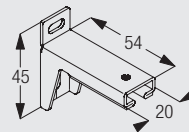

3271
Adjustable bracket
base

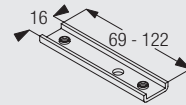

3272-74
Bracket arm

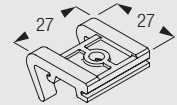

3826
Top fix bracket

Brackets 3275-3277 are a combination of bracket support 3271 and bracket arm 3272, 3273 or 3274. Brackets feature thread for screw M4x8 (6748) for fixing the bracket.

Standard Accessories

Single Parts



0562	Lead with in-line connector		2191	Profile	
3825	Clamp (35mm)		5002	Right hand overlap arm (pair stack)	
5003	Overlap arm (single stack)		5004	Overlap arm left (pair stack)	
5112	Mask for pair stack		5120	Master carrier	
5130	Driving Belt		6086	Spring stop	
6098	Roller glider with eye		9020	Motor 90-260V AC	

Sets

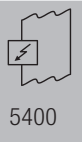
9121	Driving set for 5400, containing:	2193	Belt return set	1	
		5005	Master carrier	2	
		5110	Mask	2	
		5127	Clip	1	
		5147	Support	1	



5400

5149	Securing pin	1	
5152	Driving wheel	1	
5186	Case gear drive	1	



Optional Accessories

Single Parts

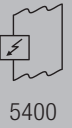



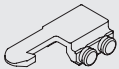
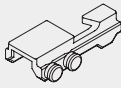

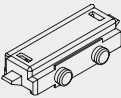
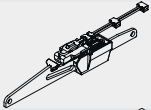
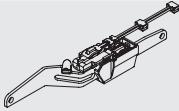
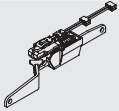

0521	Lead for klik socket		0565	Non-latching switch	
0766	In-line connector (complete/no lead)		3133	Bracket cover (60mm)	
3134	Extension bracket (60mm)		3135	Extension bracket (80mm)	
3136	Extension bracket (100mm)		3137	Extension bracket (120mm)	
3138	Extension bracket (150mm)		3139	Extension bracket (200mm)	
3271	Adjustable bracket base		3272	Adjustable bracket arm (69mm)	
3273	Adjustable bracket arm (92mm)		3274	Adjustable bracket arm (122mm)	
3826	Top fix bracket		3832	Twist clamp	
3836	Bracket (62mm)		5114	Return cover plate	
5115	Connecting bridge		5117	Recess profile	
5118	Wedge for recess profile		5185	Motor cover	
5651	Programming cable		6007	Endstop	
6083	Glider		6094	Roller glider with hook	
6098	Roller glider with eye		6268	Hanger	
6283	Roller glider		6364	Extension	



5400

6365	Hanger		6367	Master carrier	
6368	Carrier		6396	Mask	
6748	Cheese head machine screw (M4)		9021	Motor 90-260V AC with integral radio receiver	
10374	Carrier set		10375	Manual override straight set	
10376	Manual override left set		10377	Manual override right set	

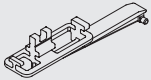
Wave and Wave XL Accessories

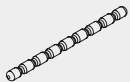
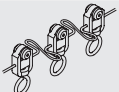
2216	Cord		3012	Hook	
3582	Hook		3599	Hook	
6004	Eyelet		6005	Hook	
6007	Endstop		6345	Wave glider cord (60mm)	
6346	Wave glider cord (80mm)		6349	Curtain tape	
5400	6363	Top hemming tape	6364	Extension	
	6365	Hanger	6367	Master carrier	
	6368	Carrier	6391	Hanger	
	6392	Heading film	6393	Glider	
	6394	Carrier	6395	Extension	
	6396	Mask	10075	Lead weight 50 gr/m	
	10076	Fabric weight	6098W	Wave roller glider cord (80mm)	

Overview Motors and Controls

Motor 9020-9021 (90-260V AC)	Standard	Option
		With built-in radio receiver
Motor Nr.	9020	9021 / 9021 EL

Motor Features

Interference free	•	•
Electronic limit settings (with memory to protect against power failure)	•	•
Thermal overload protection	•	•
Meets the standards ETL/UL, CE/IECEE-CB, CCC	•	•
Shaft rotation reversible	•	•
Smooth operation with soft start and soft stop	•	•
Automatic obstacle detection	•	•
2 programmable scenes (intermediate stops)	•	•
Standard status LED indicator	•	•
Can be stopped at any position	•	•

Control Features

Silent Gliss radio control 0450 / 9940		•
Other remote controls (IR, radio) with external devices possible	•	
Timer and Light sensor connections possible	•	
Suitable for all common home automation and bus systems	•	•
Switching by the mains group – no relays required (maximum 3 motors)	•	
Switching by low voltage inputs group (max. 15 motors) and individual	•	•
Mains 230V simultaneous or individual operation	•	
0900 Timer option	•	

Motor 9020 / 9021 (90-260VAC)

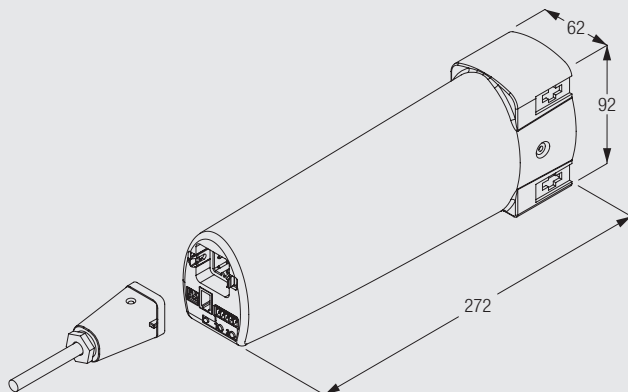

- Voltage: 90-260VAC
- Frequency: 50/60Hz
- Current: 230V, 0.5A/115V, 1.0A
- Speed: 110rpm
- Noise level: < 45dBA (30cm)
- Thermal overload protection
- ETL/UL, CE/IECEE Standard
- Electronic end stop
- 2 x programmable intermediate stops
- Weight: 1kg



5400

Note: For 9940 radio control system use integrated motor 9021EL, for 0450 radio control system use integrated motor 9021.

Operating Methods

Simultaneous control via mains switching with motor 9020

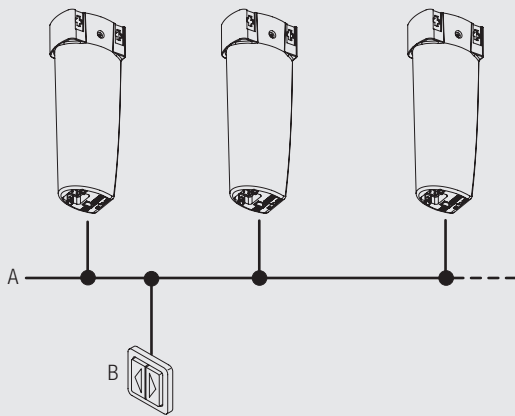

A: 90-260VAC supply (3 core + earth)
B: Switch and supply

The "Open-Close" function can only be operated by latched switch.
Electronic operation with "Open-Close" at any desired position.
Up to 3 systems can be operated via mains connections without relays
subject to suitable switches and wiring.

Individual and simultaneous operation via low voltage control with motor 9020 and 9021

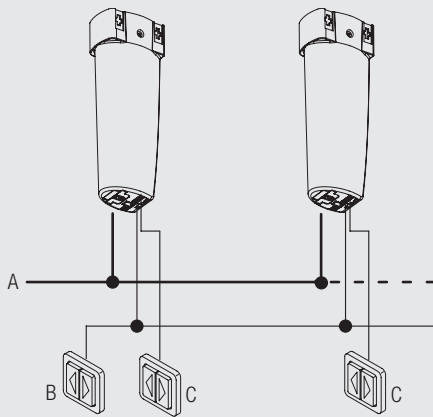

A: 90-260VAC supply (2 core + earth)
B: Low voltage simultaneous (24VDC 3 core)
C: Low voltage individual (24VDC 3 core)

Electronic operation with "Open-Close" at any desired position.
Simultaneous and/or individual operation of single or multiple systems,
by low voltage switch.
Up to 15 systems can be operated via low voltage.

5400

Radio remote control systems 9940/0450 with motor 9021 (integrated receiver)

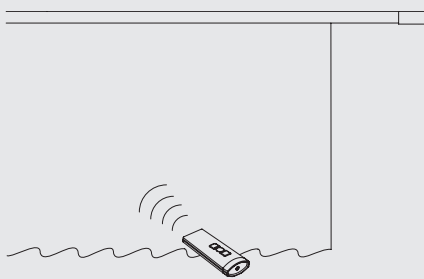

System with Silent Gliss motor 9021 features an integrated radio receiver and can be combined with Radio Remote Control Systems Silent Gliss 9940/0450 with minimum wiring. For further details, please refer to catalogue section "Motors & Controls".

Wiring Connections

Wiring diagrams are available on the Silent Gliss website www.silentgliss.co.uk (password required).



5400



5400



5400

www.silentgliss.co.uk

Silent Gliss Ltd
Pyramid Business Park
Poorhole Lane
Broadstairs
Kent
CT10 2PT
Great Britain

Tel: 0044 (0) 1843 863571
Fax: 0044 (0) 1843 864503
sales@silentgliss.co.uk